

PROFESSIONAL HD 40 TOWER

TB 95444
Professional HD 40 Tower Head

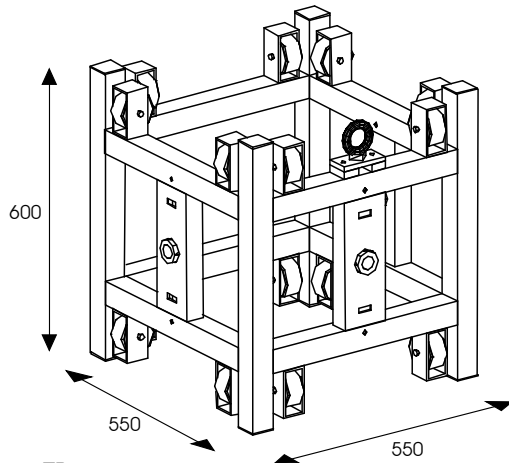
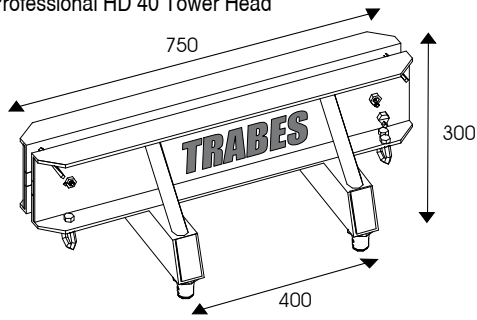

TB 95443
Professional HD 40 Sliding
Corner Block

TB 9642
Adjustable Flange
400 x 560 mm
Weight 11 kg

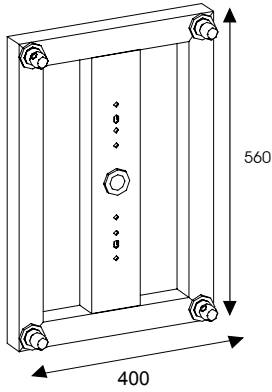

TB 98441
Adjustable Flange
for 40x40
Professional Truss
Weight kg 7,2

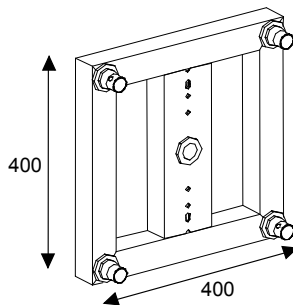

TB 9536
Tower-to-hoist case support

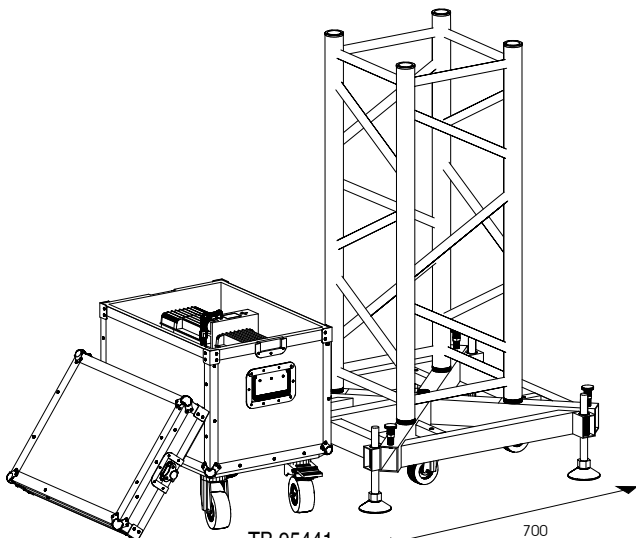
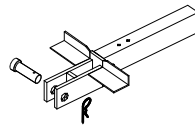

TB 95441
Professional HD 40 steel base

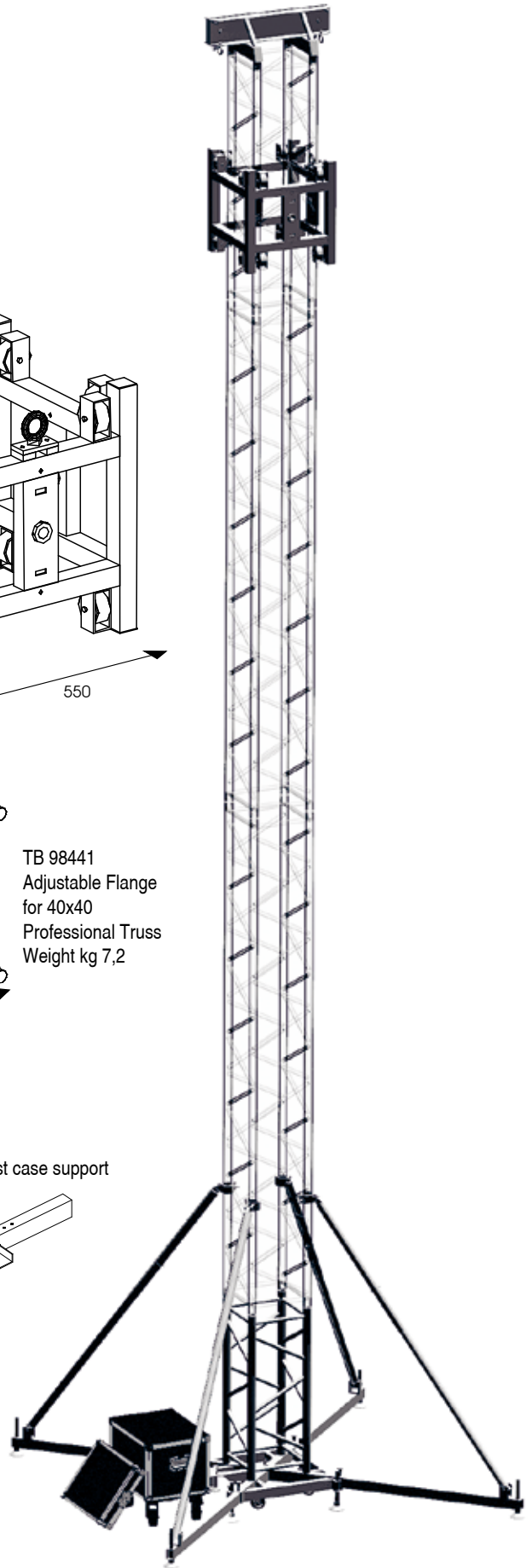

CODE	WEIGHT	DESCRIPTION
TB 95440	103,00 kg	Kit Professional HD 40 Tower with: TB 95441, TB 95443, TB 95444, TB 9536
CODE	WEIGHT	KIT DESCRIPTION
TB 95444	9,00 kg	Head (4 TA 4006 and 4 TA 8009 included)
TB 95443	20,00 kg	Sliding Corner Block 550 x 550 x H 600 mm
TB 9536	3,00 kg	Hoist case-to-tower support
TB 95441	71,00 kg	Professional HD 40 Base, 4 adjustable upwinds, hoist-to-tower support, 4 wheels Ø 80 mm, spirit level, 4 base adjustments.

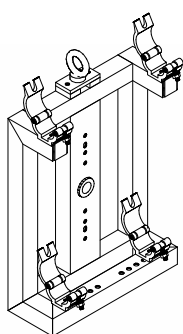

TB 9850
Side Flange for Roof
Systems with 40x56
section Truss
Weight kg 9,65

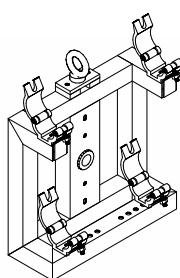

TB 9840
Side Flange for Roof
Systems with 40x40
section Truss
Weight kg 8,5

TOWER HEIGHT	LOADING CAPACITY
2 m	4500 kg
3 m	4500 kg
4 m	4500 kg
5 m	4500 kg
6 m	3200 kg
7 m	2400 kg
8 m	1860 kg
9 m	1480 kg
10 m	1200 kg

LOADING FIGURES

TB 95448
Professional HD 40
Tower's Lifter
Weight 20 kg

TB 95449
Kit: Professional HD 40
Tower's Lifter
Weight 22 kg
With:
- 1 TA 95442
- 1 TA 95448

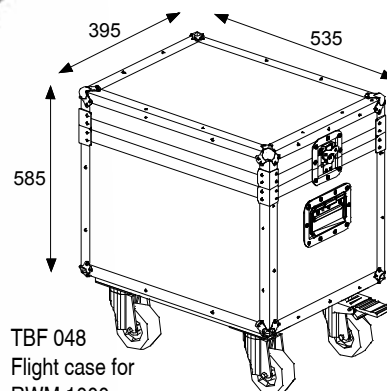

TBF 048
Flight case for
RWM 1000
Weight 17 kg

